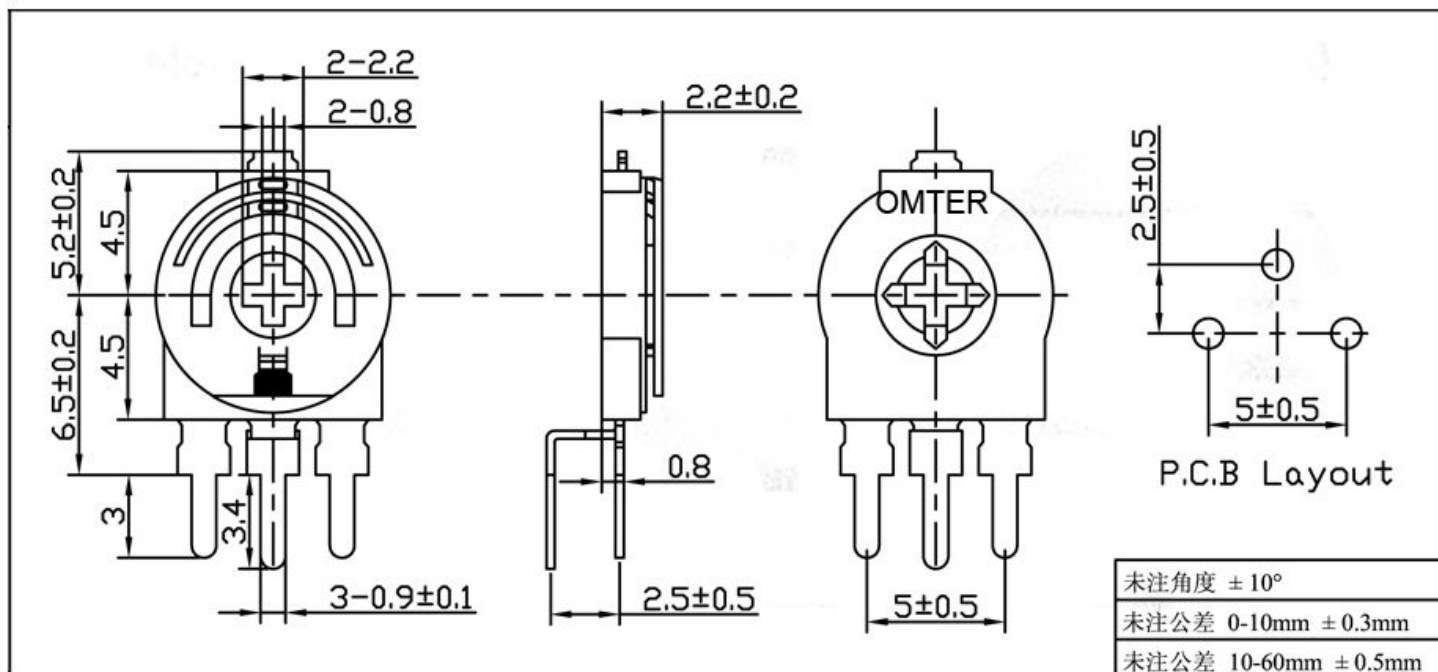

SM-083

**Feature特点:**

- ◇ 3 Pins (三端型) ◇ Vertical Mount/ Horizontal Adjust (直立/横调式)
- ◇ RoHS Compliant (环保产品, 有RoHS认证)

参数特性General Specification:

总阻值范围 Nominal Resistance	100 Ω to 2M Ω
标准阻值误差 Resistance Tolerance	$\pm 30\%$ standard
残留阻值 Residual Resistance	Maximum 5% of Nominal Resistance, but less than 30 Ω
线性 Taper	Linear (B)
额定功率 Power Rating	0.1W
使用电压 Operating Voltage	Less than (少于) 50V
旋转寿命 Rotational Life	Maximum $\pm 15\%$ change in Nominal Resistance after 100 Cycles
负载寿命 Load Life	Maximum $\pm 5\%$ change in Nominal Resistance after 3 hours loaded
旋转角度 Rotational Angle	$270^\circ \pm 20^\circ$
扭转力矩 Torque	30 ~ 350 g.cm
止挡强度 End-Stop Strength	500g.cm (Min.)
机械强度 Mechanical Strength	Bakelite sheet not be broken down under pressure of 1Kg. cm maximum
使用温度 Operating Temperature	$-5^\circ\text{C} \sim +40^\circ\text{C}$
温度特性 Temperature Characteristics	$+5 \sim -30\%$ change in resistance after 5 hours at 70°C
湿度特性 Humidity Characteristics	Maximum 20% Change in Resistance after 350 hours at 40°C and RH 90% loaded
焊锡方式 Soldering Method	Hand Soldering